

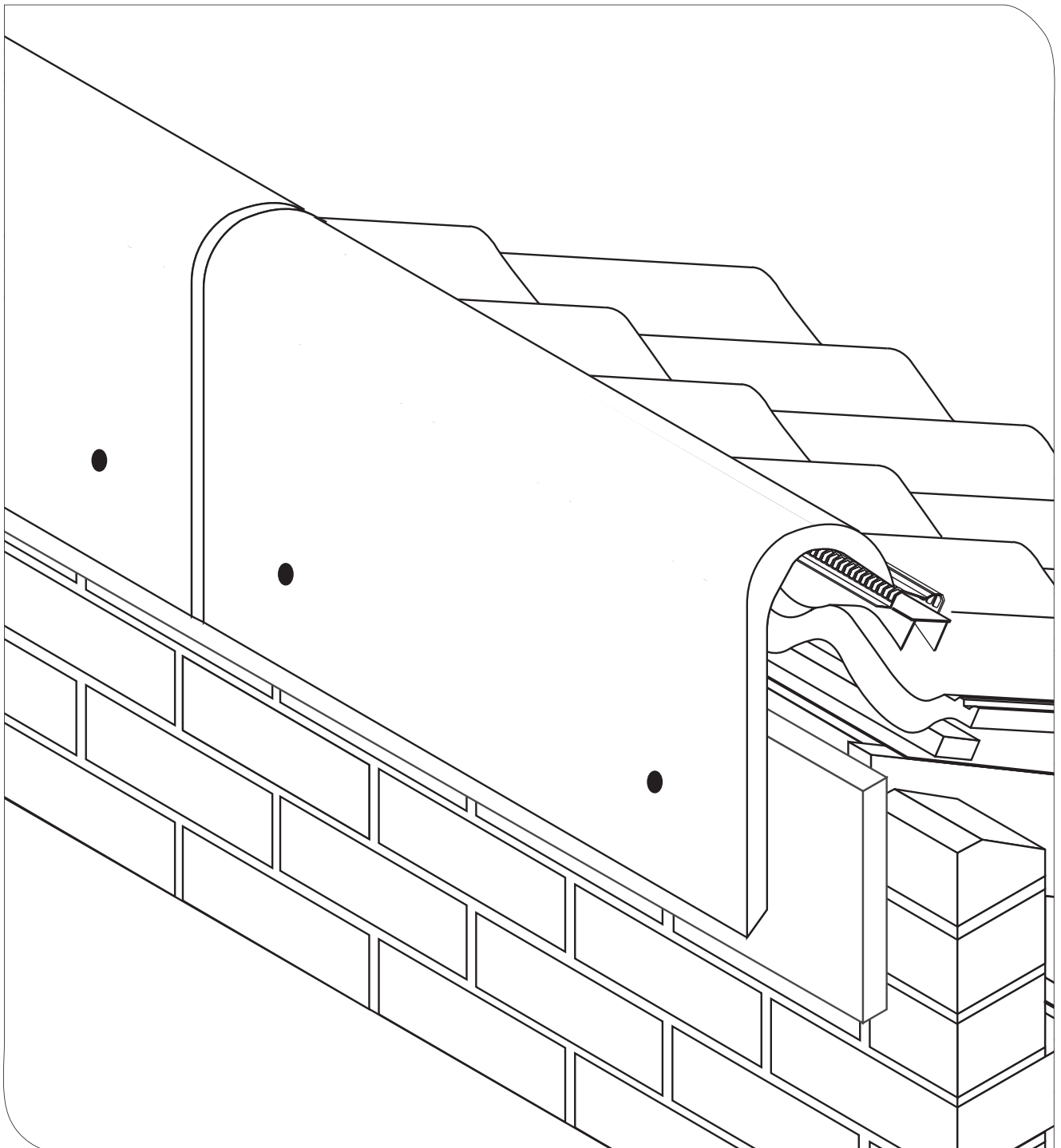

Sandtoft

**Installation guide for
Sandtoft Profile Mono Ridge**



Installation guide for Sandtoft Profile Mono Ridge

The Profile Mono Ridge system incorporates ventilation strips to support the mono ridges and provide high level ventilation. Mono ridge unions provide an efficient seal between each mono ridge and give the appearance of a 10 mm joint. To complete the system and to enhance aesthetics, profile fillers are supplied for profiled tile types. The fillers click into the ventilation strips and both are marked to ensure correct orientation.

Contents per 2.7 metre pack:

- 3 ventilation strips
- 6 mono ridge unions (9 for use with 305 mm mono ridges)
- 12 spacer washers (18 for use with 305 mm mono ridges)
- Quantity of profile fillers depends on tile width

Components

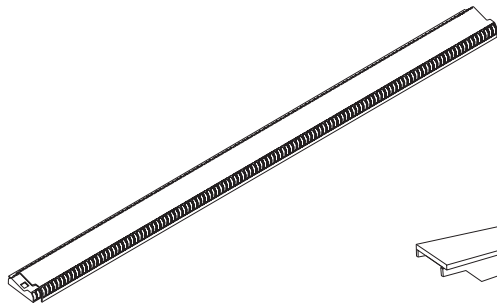

Ventilation strip

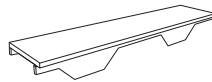

Profile filler



Spacer washer

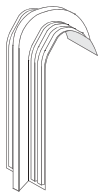

Clay half round mono ridge union

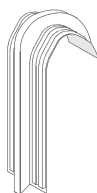

Concrete/Duracoat half round mono ridge union

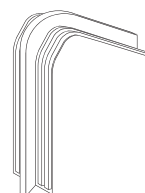

Concrete/Duracoat legged angle mono ridge union

Installation

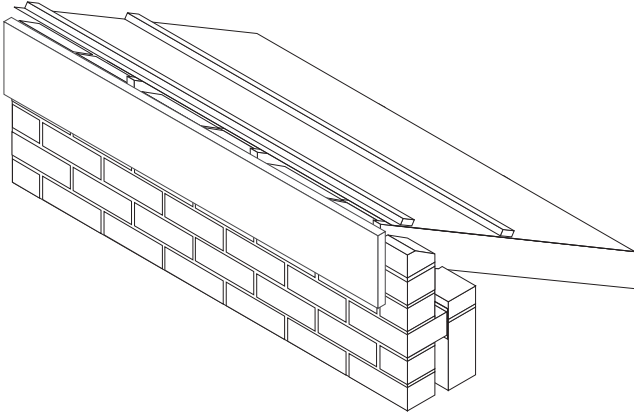

1. Lay top course of underlay. Set back 30 mm from the mono ridge apex where roof space ventilation is required.

Fix the top course tile or slate battens. Set the position to ensure that the mono ridges cover the top course of tiles/slates by at least 75 mm.

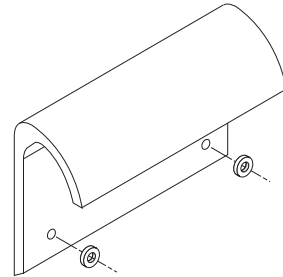

3. Remove backing paper from spacer washers and fix over holes on inside of mono ridges and block end mono ridges.

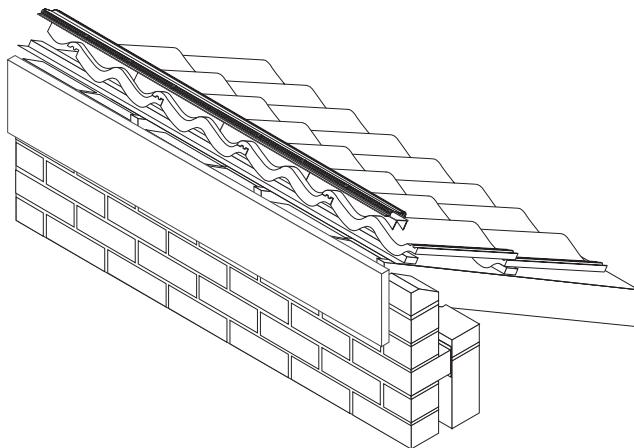

2. For profiled tiles, click the profile fillers into the ventilation strips. Then click the ventilation strips together end to end and position on to the top tile or slate course. Make sure they are facing the correct way – for ease of use, both the profile fillers and the ventilation strips have arrows which must point towards the ridge.

(For use with County Pantiles, see additional information overleaf).

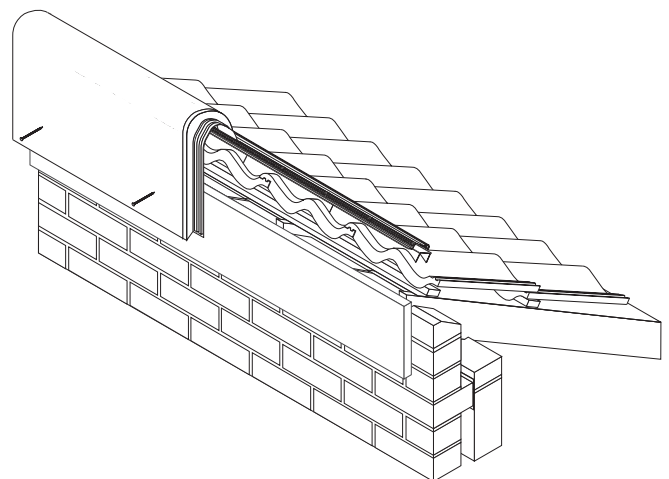

4. Fit a block end mono ridge onto the ventilation strip and then fit a mono ridge union under the open end of the block end mono ridge.

Secure the block end mono ridge using nails or screws through the two holes in the back leg of the mono ridge.

(The fixings are not provided as the type will depend upon the material being fixed to: for example, timber fascia, masonry wall, metal decking etc.).

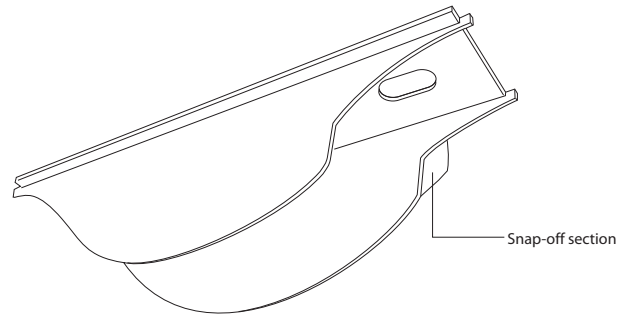
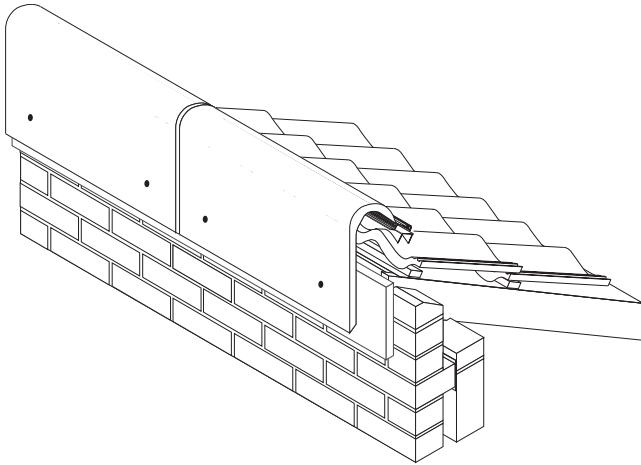

5. Locate the adjacent mono ridge over the mono ridge union and onto ventilation strips. Secure using nails or screws through the two holes in the back leg of the mono ridge.

Continue fixing in the same way.

Additional information for the County Pantile Profile Mono Ridge

The County Pantile profile filler is designed for use with either full standard tiles or with cut tiles where a full course cannot be set out at the ridge. If it is not possible to fix a full course then the heads of the tiles can be removed. The tiles must then be drilled to achieve a nail fixing into the tile batten. The profile fillers can be fitted in any position on the tiles by removing the small, snap-off section.

Technical enquiries

Tel 0870 145 2021

Fax 0870 145 2019

E-Mail technical@sandtoft.co.uk



**CAMPAIGNING FOR
BEAUTIFUL ROOFS**

At Sandtoft we are continually innovating and improving our product range. We reserve the right to change product specifications without notice. Please contact our Customer Support Team for the latest information or visit www.sandtoft.com